



# RE MAR QUE

VISUAL ANNUAL OF  
FLORIDA ATLANTIC  
UNIVERSITY  
ISSUE 10 | 2022

Graphic Design  
Studio Art  
Architecture  
Film, Video & Multimedia

VISUAL  
ANNUAL  
OF  
**FLORIDA  
ATLANTIC  
UNIVERSITY**



---

Funding provided by:  
**Department of Visual Arts and Art History**  
**Dean's Office, Dorothy F. Schmidt**  
**College of Arts and Letters**  
**FAU Broward Administration**

Remarque Staff

<b>Melanie Castro</b>	Editor-in-Chief
<b>Shelby Cochran</b>	President
<b>Thomas Brady</b>	Layout Editor
<b>Judyan Centeno Trevino</b>	Layout Editor
<b>Jordan Ducran</b>	Layout Editor
<b>Hunter Hull</b>	Layout Editor
<b>Gabriela Juarez</b>	Layout Editor
<b>E McCollum</b>	Layout Editor

Faculty Advisor

**Stephanie Cunningham** Professor of Graphic Design

Contact

**To find out more about Remarque, please contact:**  
fauremarque@gmail.com or join on Owl Central

Follow Us

Facebook: FAU Remarque / Designers' Edge  
Instagram: FAU\_Remarque

## Special Thanks

**Dan Duarte**, BFA '12 Founder of Remarque  
**John Bernasconi**, BFA '12 Founder of Remarque  
**Carlos Francisco**, BFA '13 Masthead Design  
**Astrid Maldonado** Cover Image  
**Joel Nakamura** Guest Speaker & Juror  
**Daniel Bolojan** Architecture Juror  
**Shermeen Yousif** Architecture Juror

## Staff Note

Once more, an issue of *Remarque* is yours to claim. This year's issue is special because it marks ten years of showcasing and publishing students' work! Behind it all is a group of wonderful people with an energy exciting enough to match a circus. We jumped through flaming hoops, walked on tightropes and juggled a million things at once. All of this while being stared down by a lion with its cage open; in other words, life leading up to and post-graduation. However, amidst the chaos, we kept sight of what it means to be a team. We spent months communicating and collaborating. Now, we celebrate the hard work our peers have put forth. We celebrate what it means to create and this journal is your invitation to join us in doing so.

*Remarque* '22 proudly presents enthralling studio art, rich graphic design, striking architecture as well as stunning works from film, video and new media. This university is home to so much talent it's intimidating yet also comforting and inspiring. All of these works were once simple visions that over time developed lives of their own. As such, our only wish is that you take the time to appreciate them as much as we do.

To the students and (now) alumni who played a part in the production of this year's magazine, my heart goes out to you. It was a challenge you willingly accepted while preparing for the *Mirai* and *Geist* BFA exhibitions. This issue is a testament to your resolve. To our esteemed faculty advisor, thank you so much for your patience and guidance. Your dedication to *Remarque*'s evolution is a beacon for those to follow. On behalf of the staff, I express my deepest gratitude to all who submitted their work and a hearty congratulations to those featured. Please continue to take pride in your work and aim high. Lastly, to you reading this, I hope this issue motivates you to keep honing your craft with fervour. Who knows? Perhaps the next time you find yourself will be within these pages.

Here's to ten years of *Remarque* with many more to follow. Until next time, keep on keeping on.

Jordi Ducran  
BFA Graphic Design, Fall '21

**04** GUEST JUROR

---

**05** GRAPHIC DESIGN

---

**29** STUDIO ARTS

---

**37** ARCHITECTURE

---

**49** FILM, VIDEO & NEW MEDIA

---



## GUEST JUROR



On April 6, 2022 Illustrator Joel Nakamura joined FAU Graphic Design online to share his work and talk about his career. An award winning artist, Joel Nakamura is known for his distinctive illustration style. His works have been featured in numerous publications and also featured during the 2002 Winter Olympics opening and closing ceremonies in Salt Lake City, Utah. He has been profiled in *Communication Arts*, *Step Inside Design*, *Confetti* and *Southwest Art* magazines. He has also published three books and coloring book. Nakamura lives in Santa Fe, New Mexico and splits his time between commercial and fine art projects. His work is included in numerous collections, including Wynonna Judd, Chick Corea, and US embassies around the world.

Joel serves as the special juror for this tenth issue of *Remarque*. Visit his website to see more of his amazing work.

[www.joelnakamura.com](http://www.joelnakamura.com)

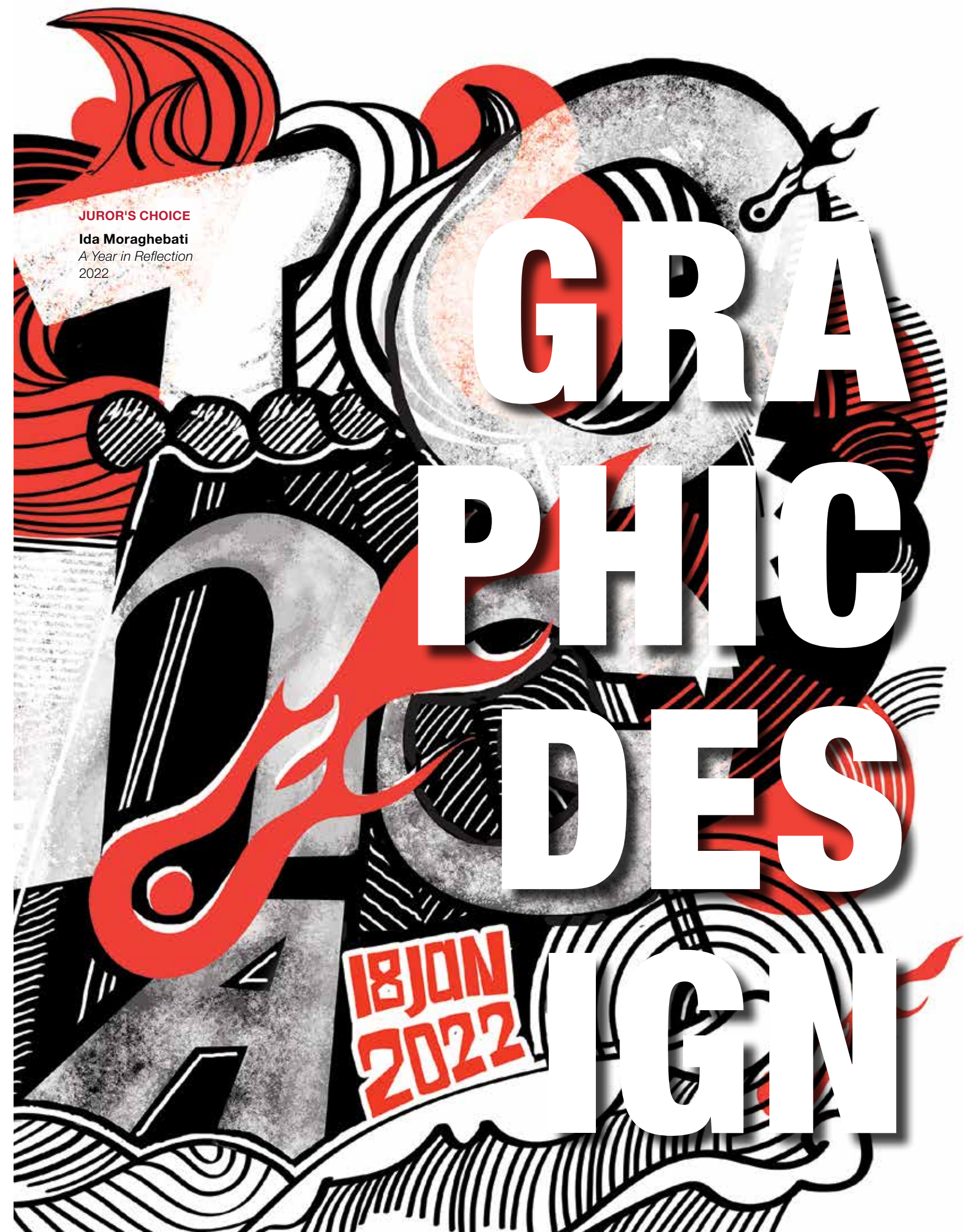
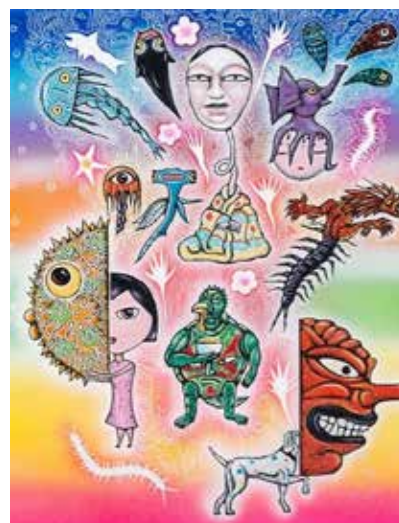

### JUROR'S CHOICE

Ida Moraghebati  
*A Year in Reflection*  
2022



# GRAPHIC DESIGN

Luis Alexander  
World Aids Museum  
Rebrand  
2022



# GRAPHIC DESIGN

**Thomas Brady**  
*Ocean's 11 (1960)*  
Title Sequence  
2021

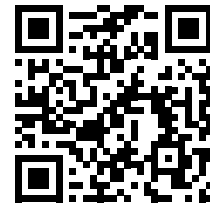

**JUROR'S CHOICE**  
**Kalliyon Jordan**  
*BFA Geist Exhibition*  
Invitation  
2022



# GRAPHIC DESIGN



**Luis Alexander**  
*Magazine Spreads*  
2022



**Annalyse Botte**  
*Found Type-Merry*  
2022

**Annalyse Botte**  
*Found Type-Fragrant*  
2022



**JUROR'S CHOICE**  
**Annalyse Botte**  
*Found Type-Ethereal*  
2022



# GRAPHIC DESIGN

**Kalliyen Jordan**  
Ohana Surf Shop Logo  
Redesign  
2022



**Marwine Jean-Paul**  
Graphic Design Today  
2022



**Thomas Brady**  
FAU Donor Wall  
2021

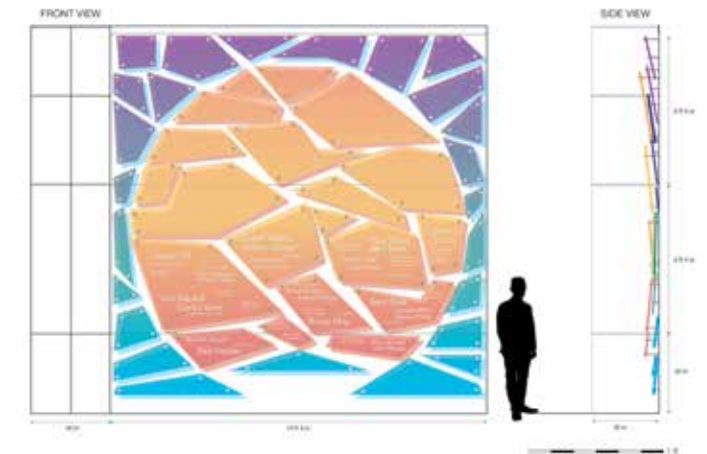
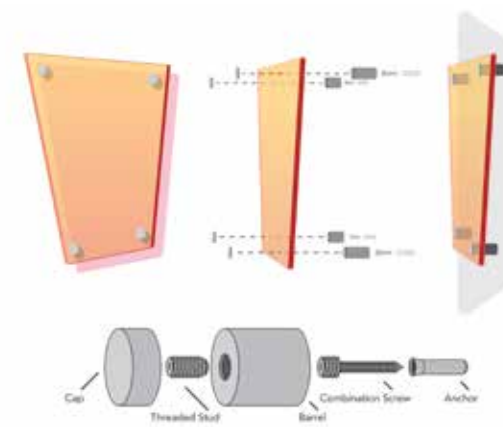
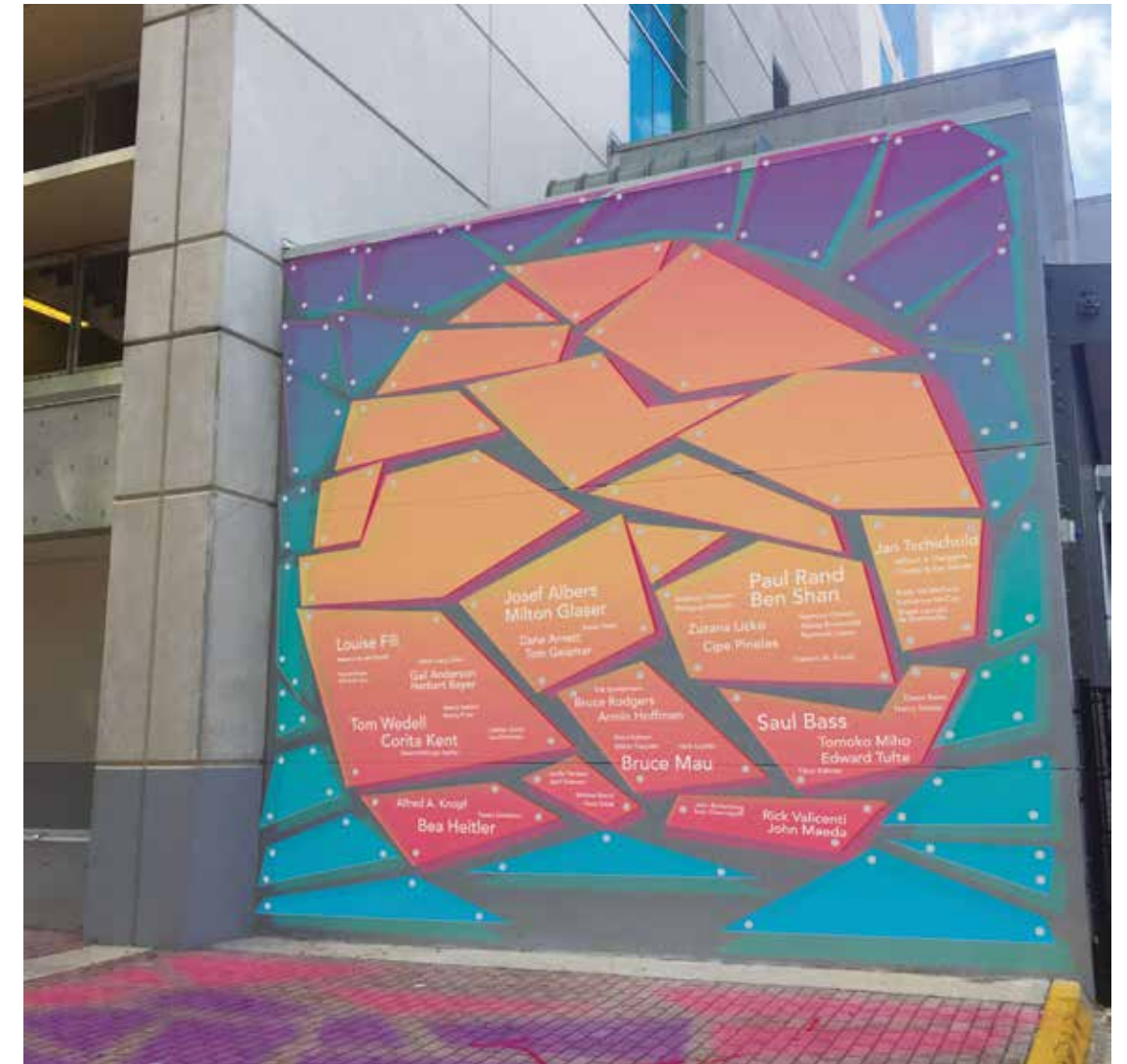



# GRAPHIC DESIGN

**Michelle Carmona**  
Relief Pairing App  
and Webpage  
2022



**Michelle Carmona**  
Relief Pad  
2022



**JUROR'S CHOICE**

**Luis Alexander**  
Up App and Webpage  
2022





# GRAPHIC DESIGN

Luis Alexander  
Subscription Box  
2022

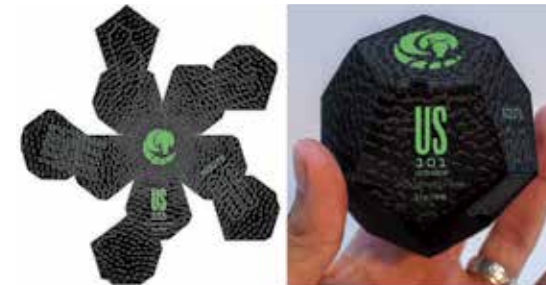

Thomas Brady  
DreamStream App  
and Webpage  
2022





Thomas Brady  
Conspicuous Magazine  
2022



Michelle Carmona  
Manti Packaging  
and Graphics  
2022





Melanie Castro  
Deborah Sussman  
Magazine Spreads  
2022

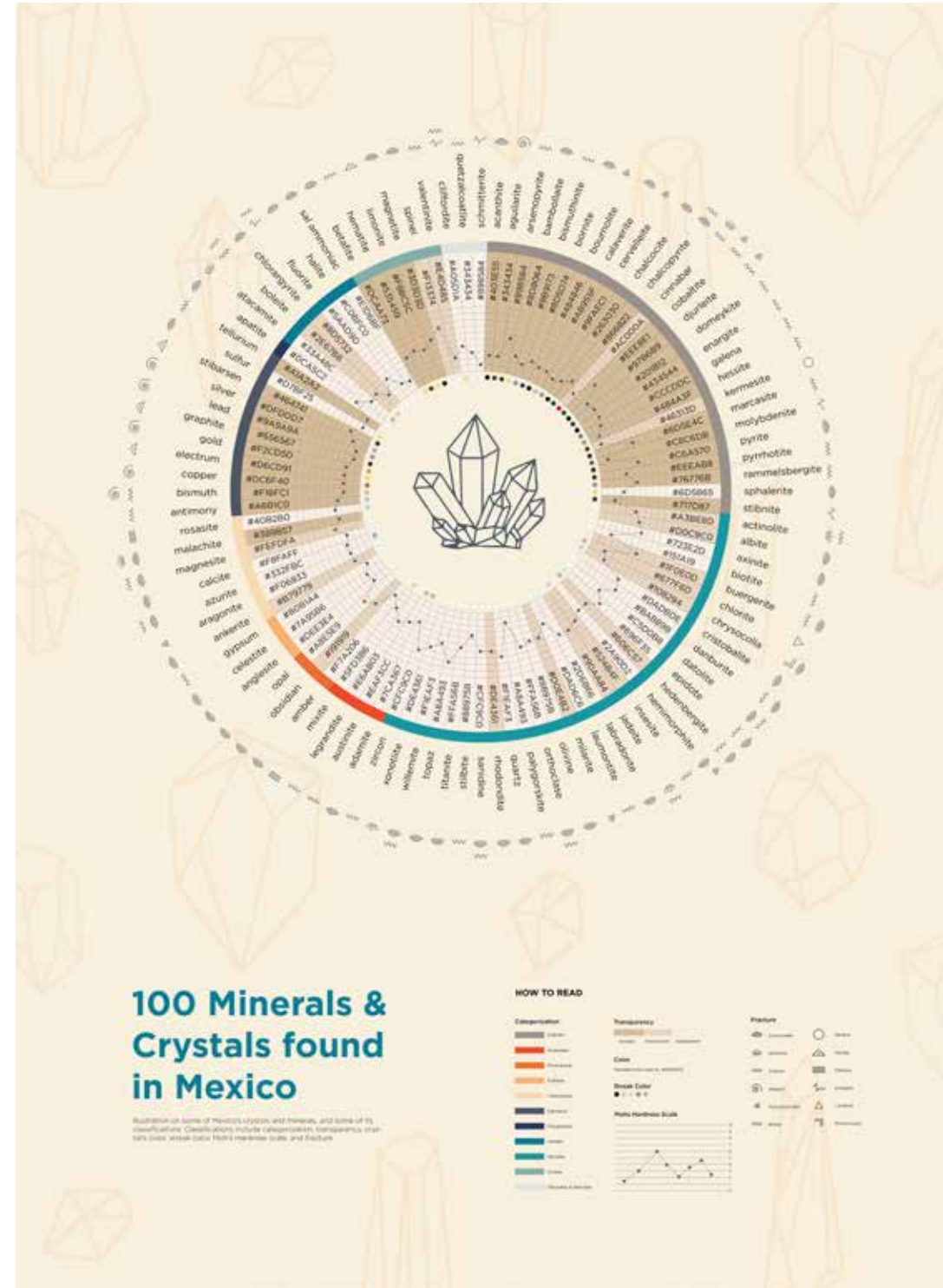

Judyana Centeno Trevino  
100 Crystals & Minerals  
Found Infographic  
2022



# GRAPHIC DESIGN

**Shelby Cochrane**  
Swamp Addict Outdoors  
Logo and Stationery  
2022





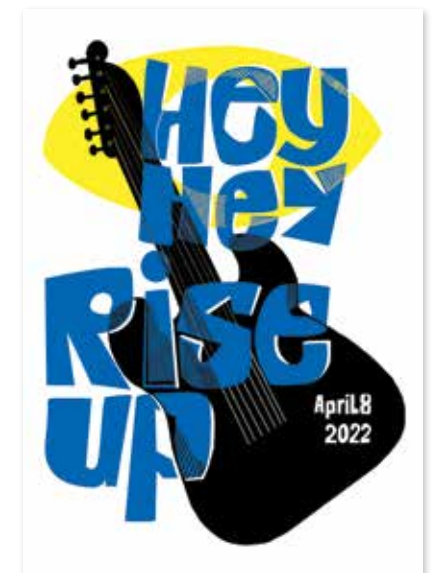

**JUROR'S CHOICE\***

**Ida Moraghebati**  
*A Year in Reflection:*  
January 12, 2022\*  
February 15, 2022  
February 25, 2022  
April 8, 2022



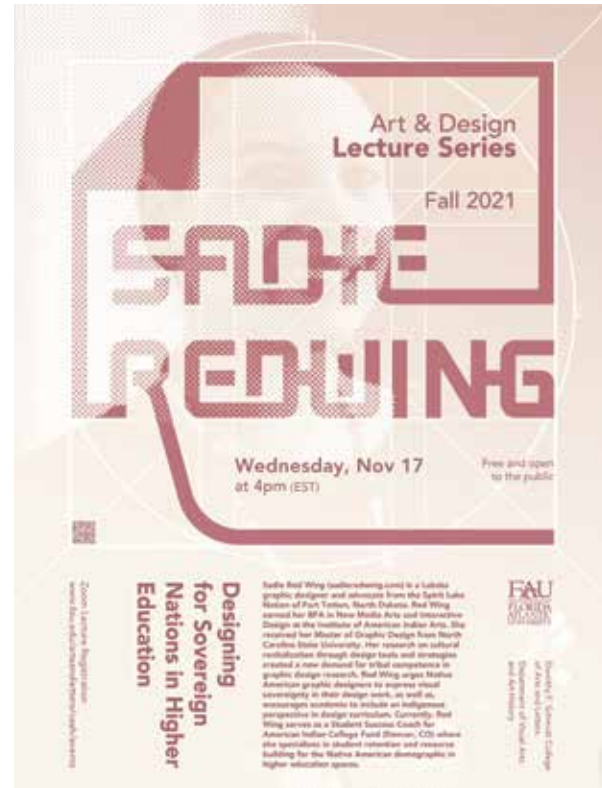
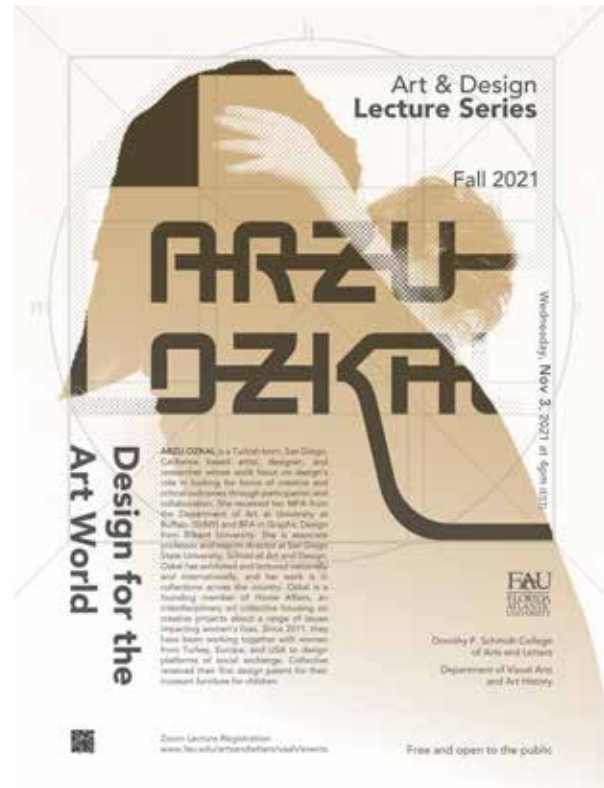

Hamed Edalati Tabrizi  
Lecture Series  
2022

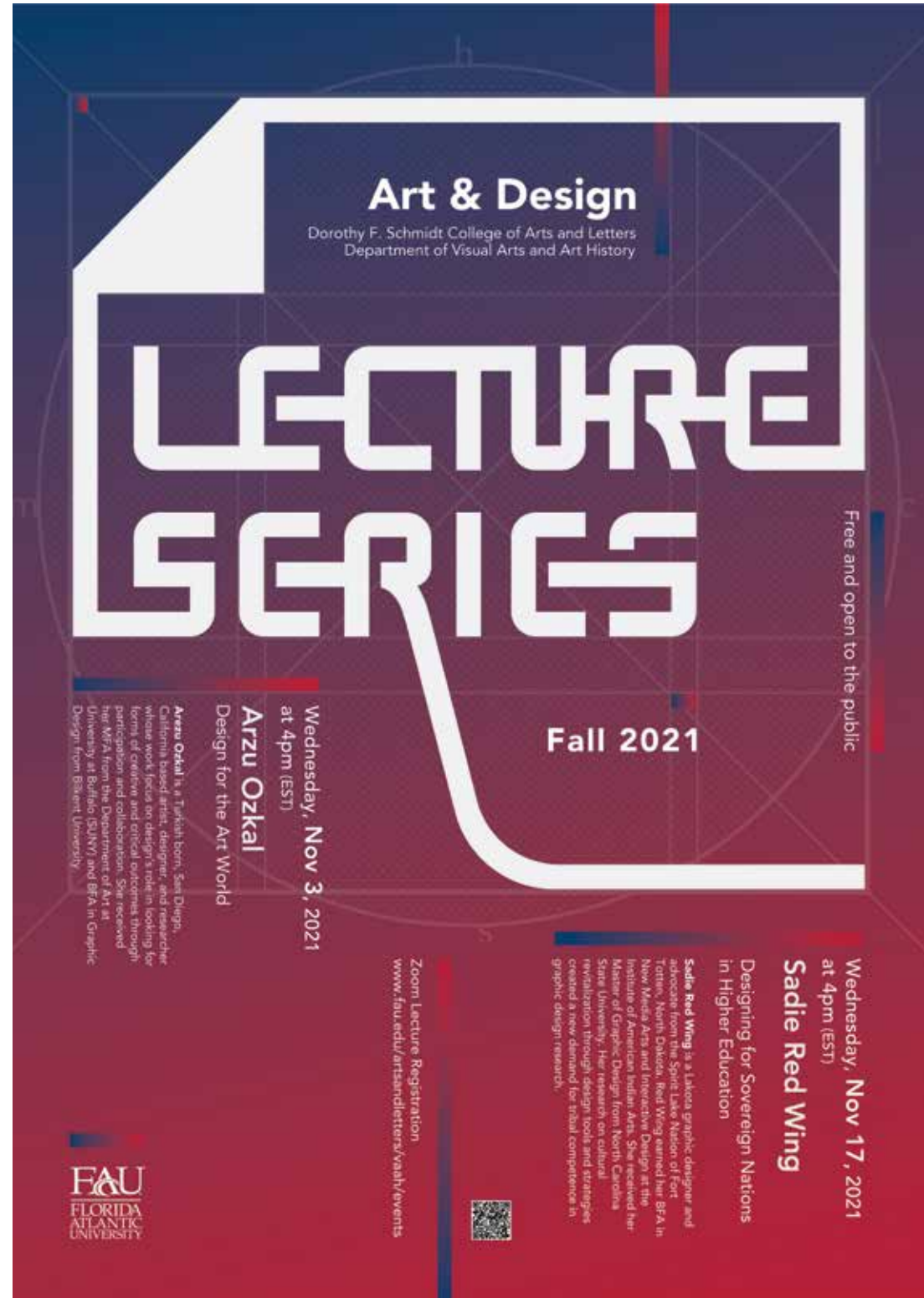



## GRAPHIC DESIGN

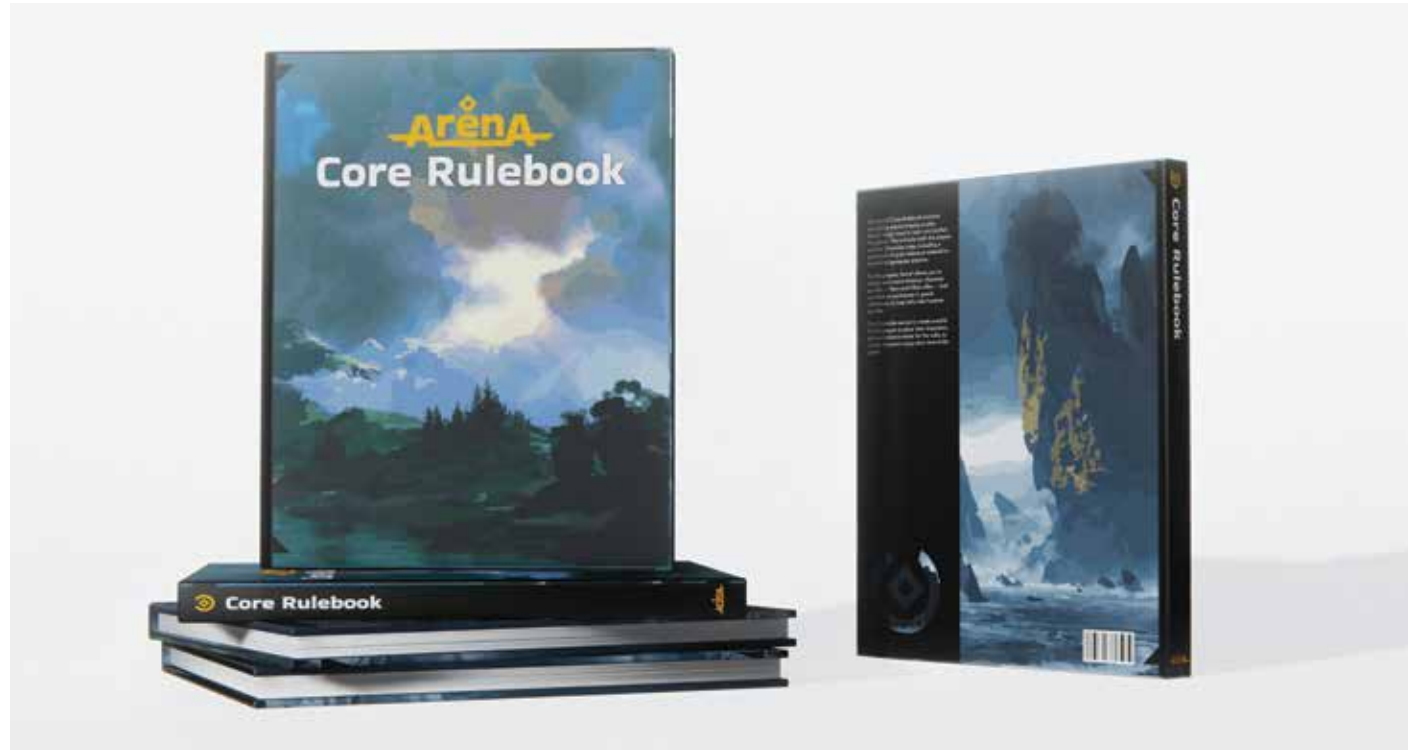

**Ian McCollum**  
*Arena Rulebook Cover*  
2022



**Ian McCollum**  
*Run Cardgame Design*  
2022



**Ray Corniel**  
*Art of the Youth*  
2022



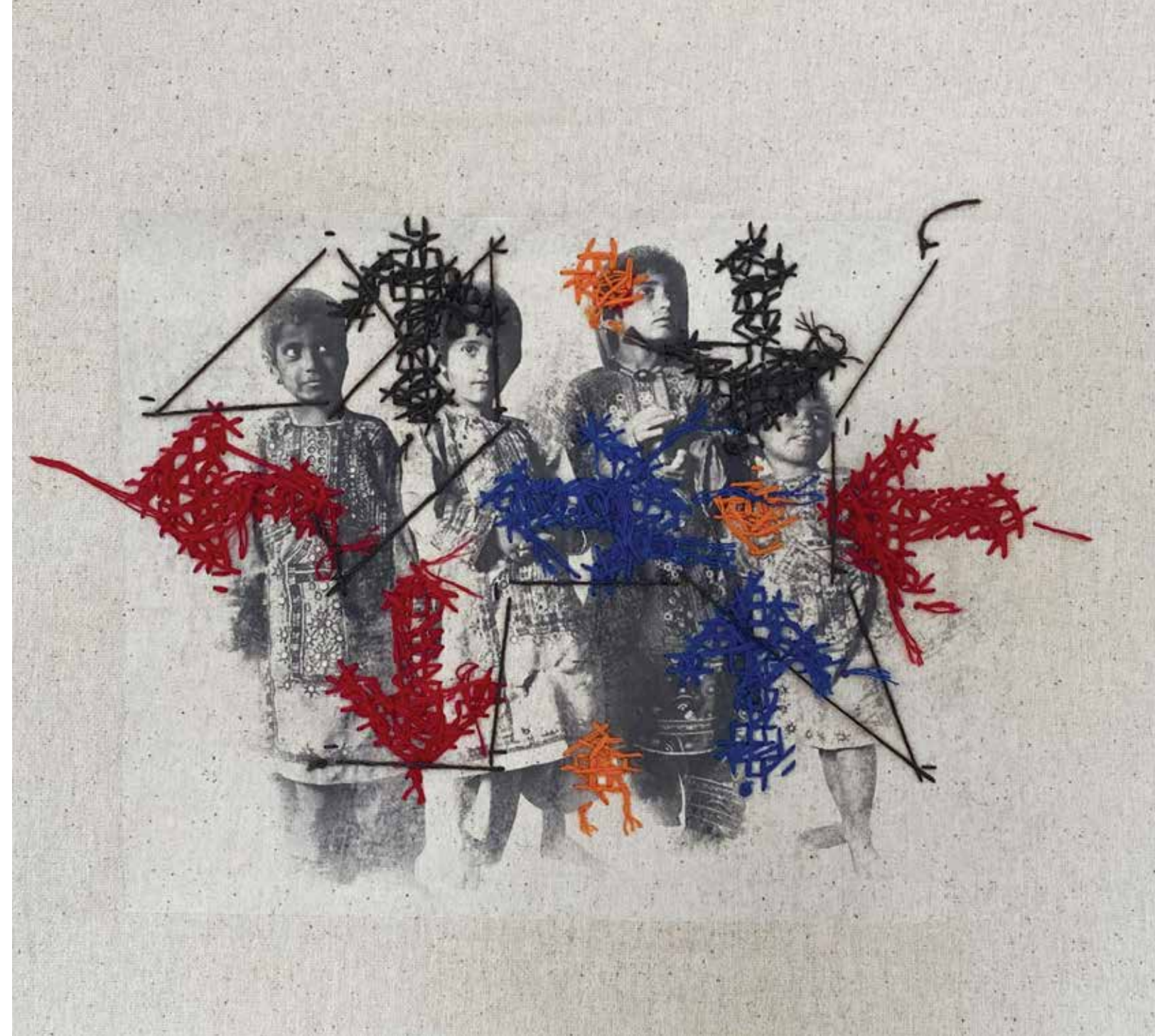

**JUROR'S CHOICE**

**Narges Panahandeh**

*Dream of Embroidery*

2022





**Shelby Cochrane**  
*Book Shelf Still Life*  
2022

**JUROR'S CHOICE**  
**Rossiny Iyeun Llopiz**  
*Threshold*  
2022





# PHOTOGRAPHY



**Gianfranco Roy**  
*A Drifting Thought*  
2022

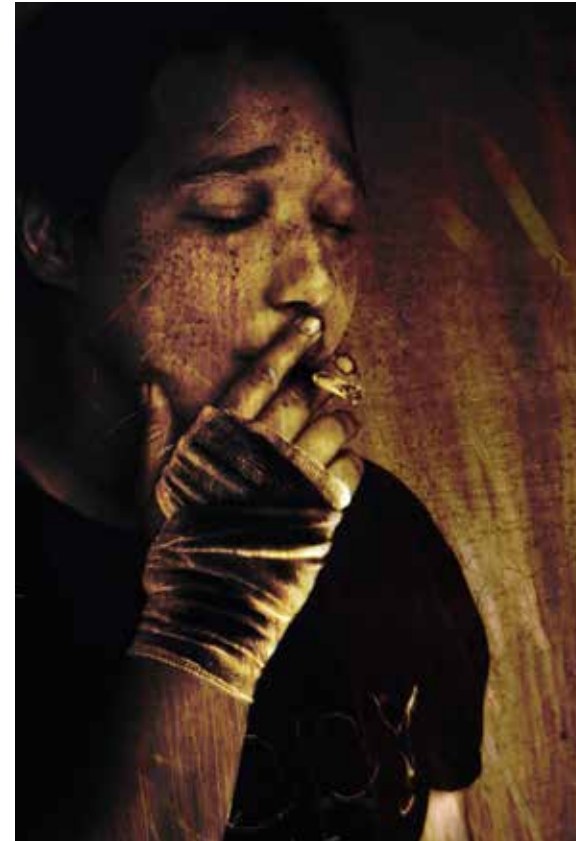

**Celeste Bandy**  
*Hurt*  
2022

**Celeste Bandy**  
*Changing*  
2022







**Juno Sorell**  
*I Am My Own Father*  
2022

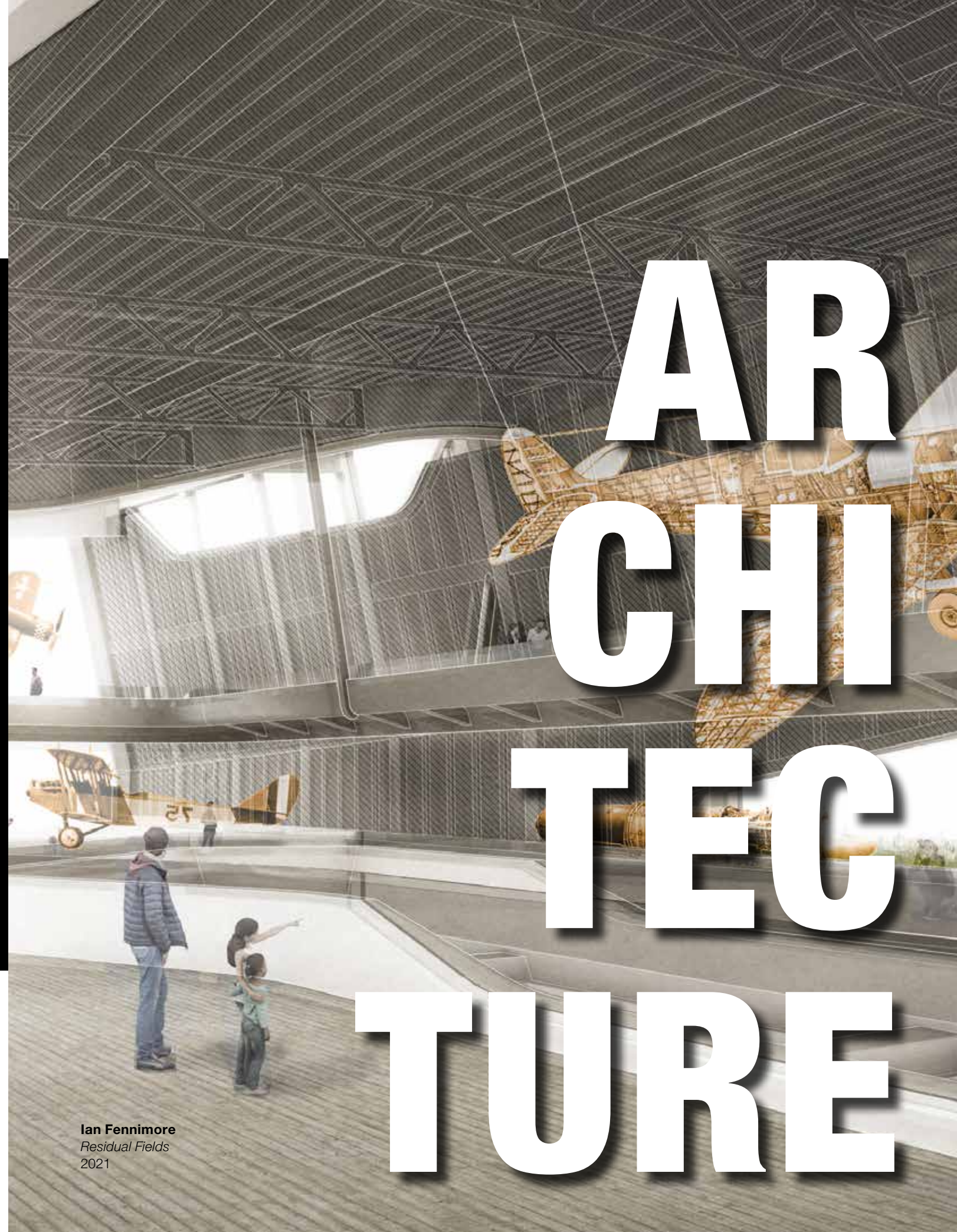

# AR CHI TEC TURE

**Ian Fennimore**  
*Residual Fields*  
2021





both pages:  
**Jerrica Arias**  
*ILYA [I Love You, and]*  
 2021

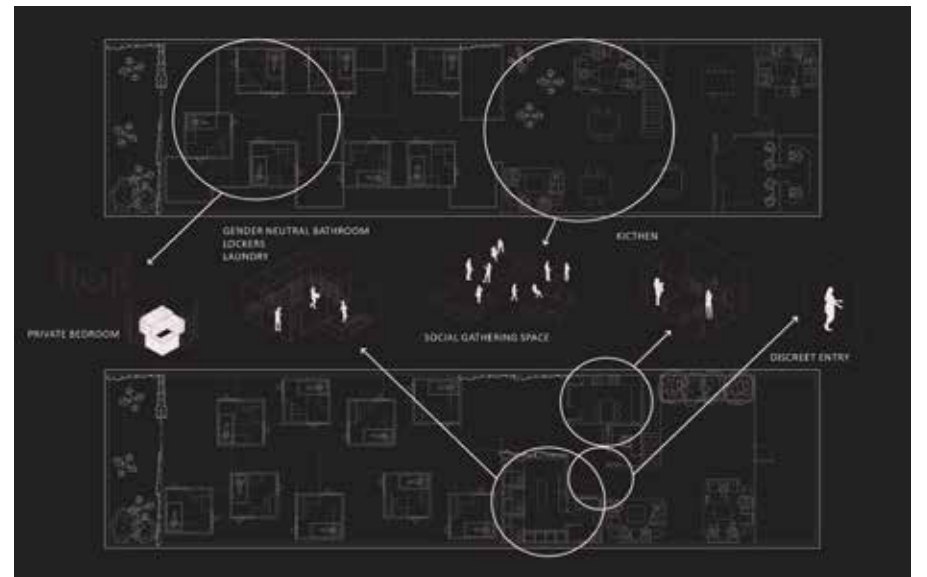
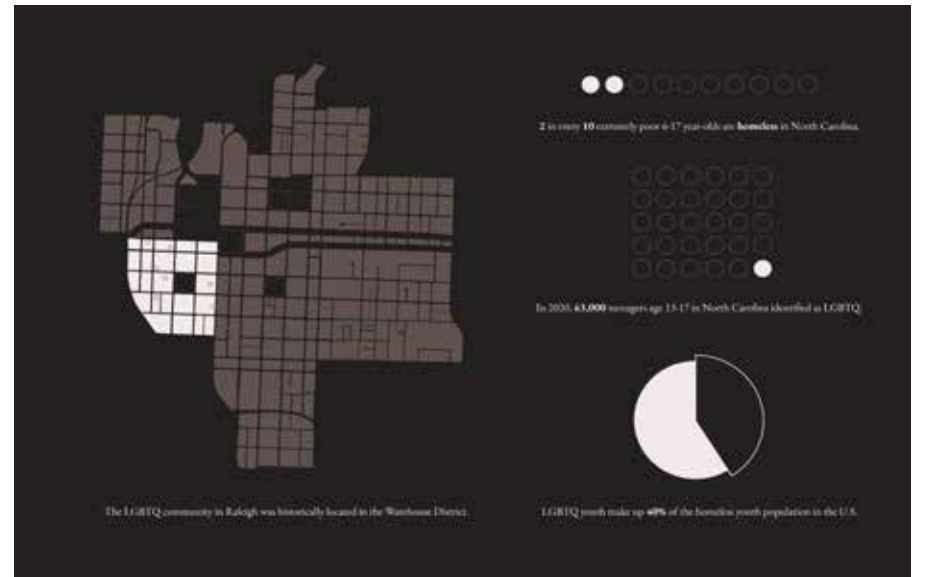



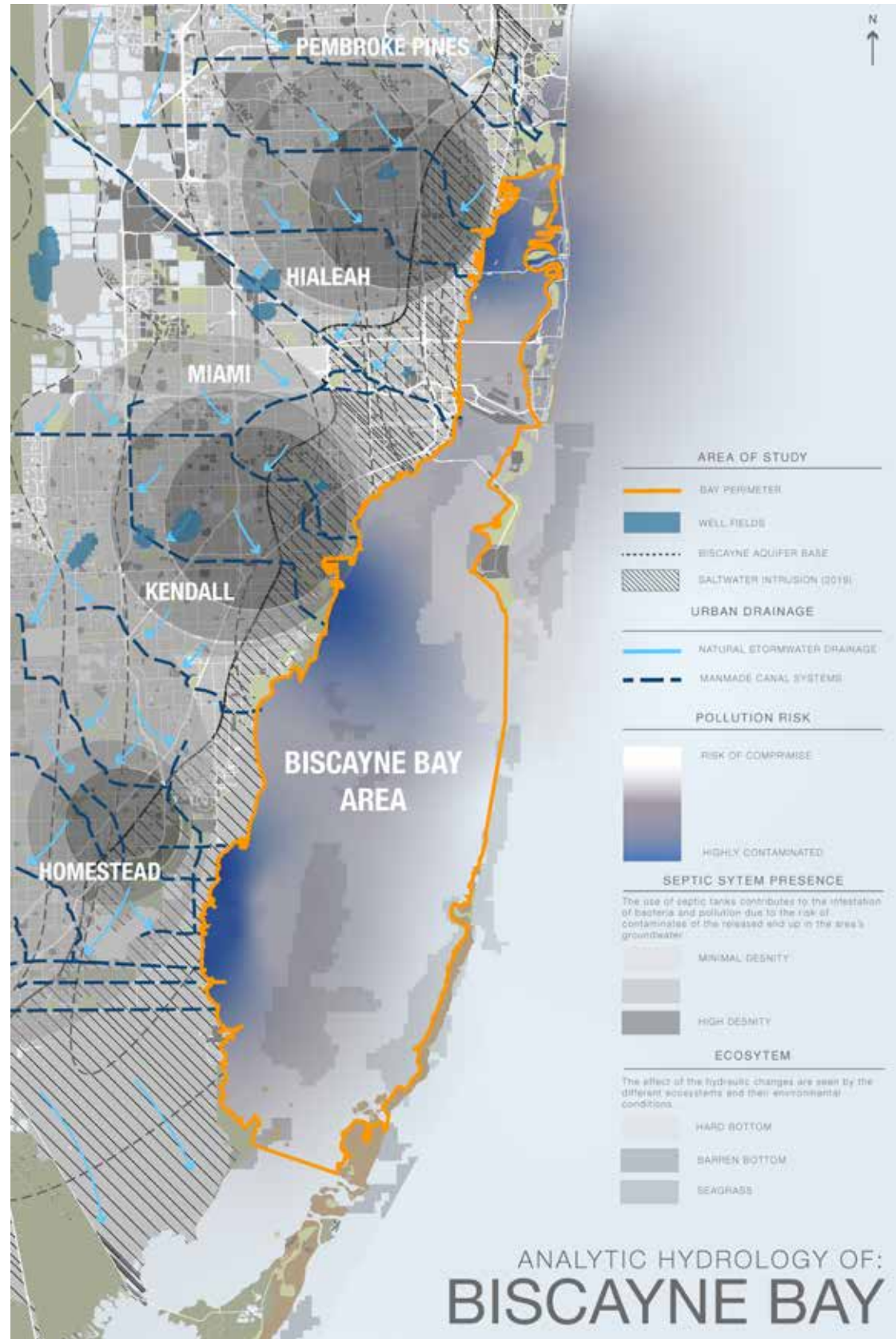

Jerrica Arias  
Analytic Hydrology  
of Biscayne Bay  
2022

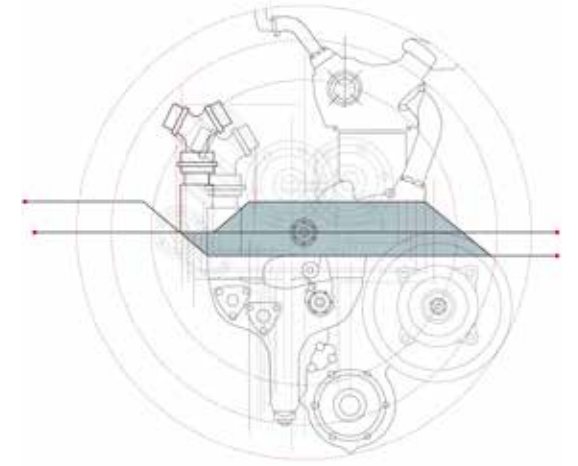

Jerrica Arias  
Transtemporal  
2021



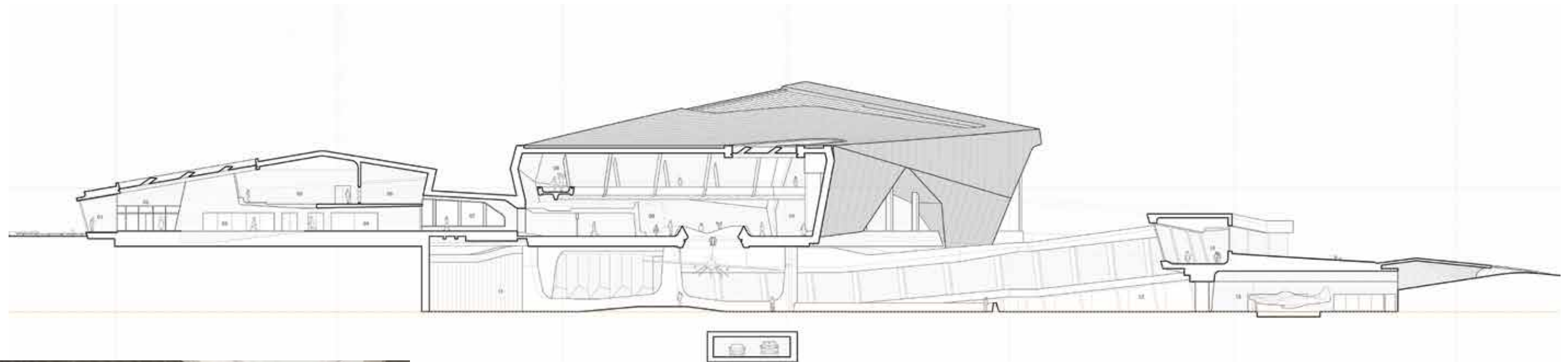

**JUROR'S CHOICE**

both pages:  
**Ian Fennimore**  
*Residual Fields*  
2021



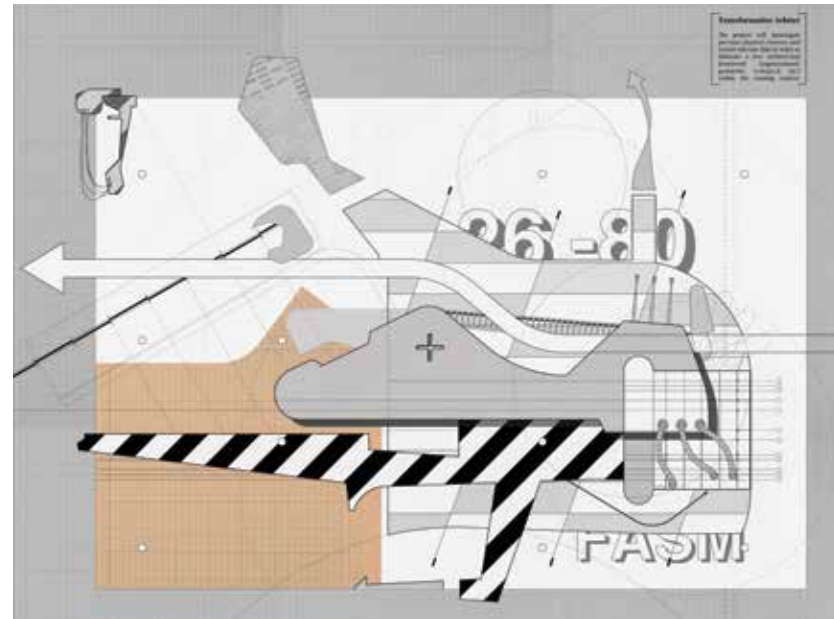
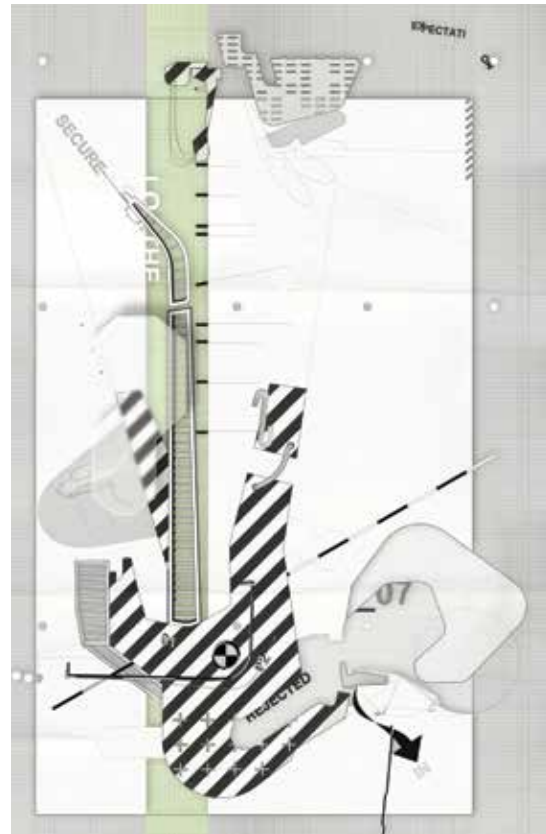
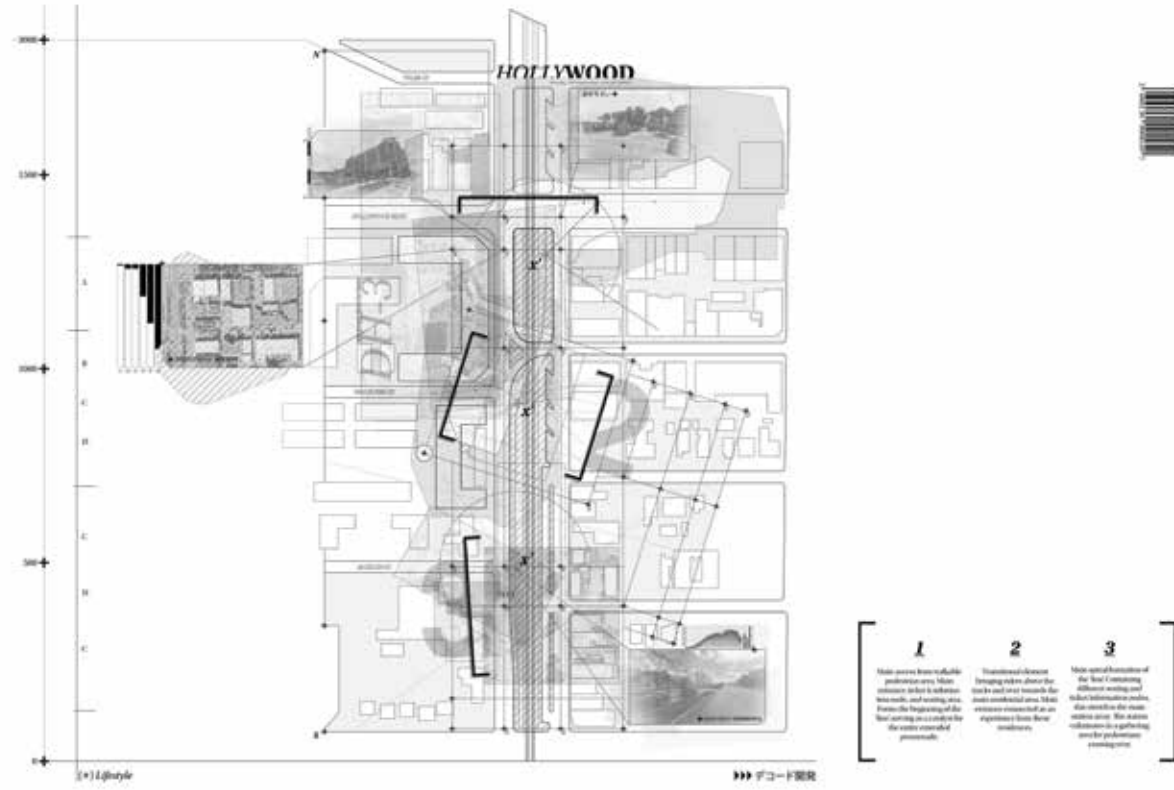

**Ian Fennimore**  
*Allegorical Drawings*  
2021

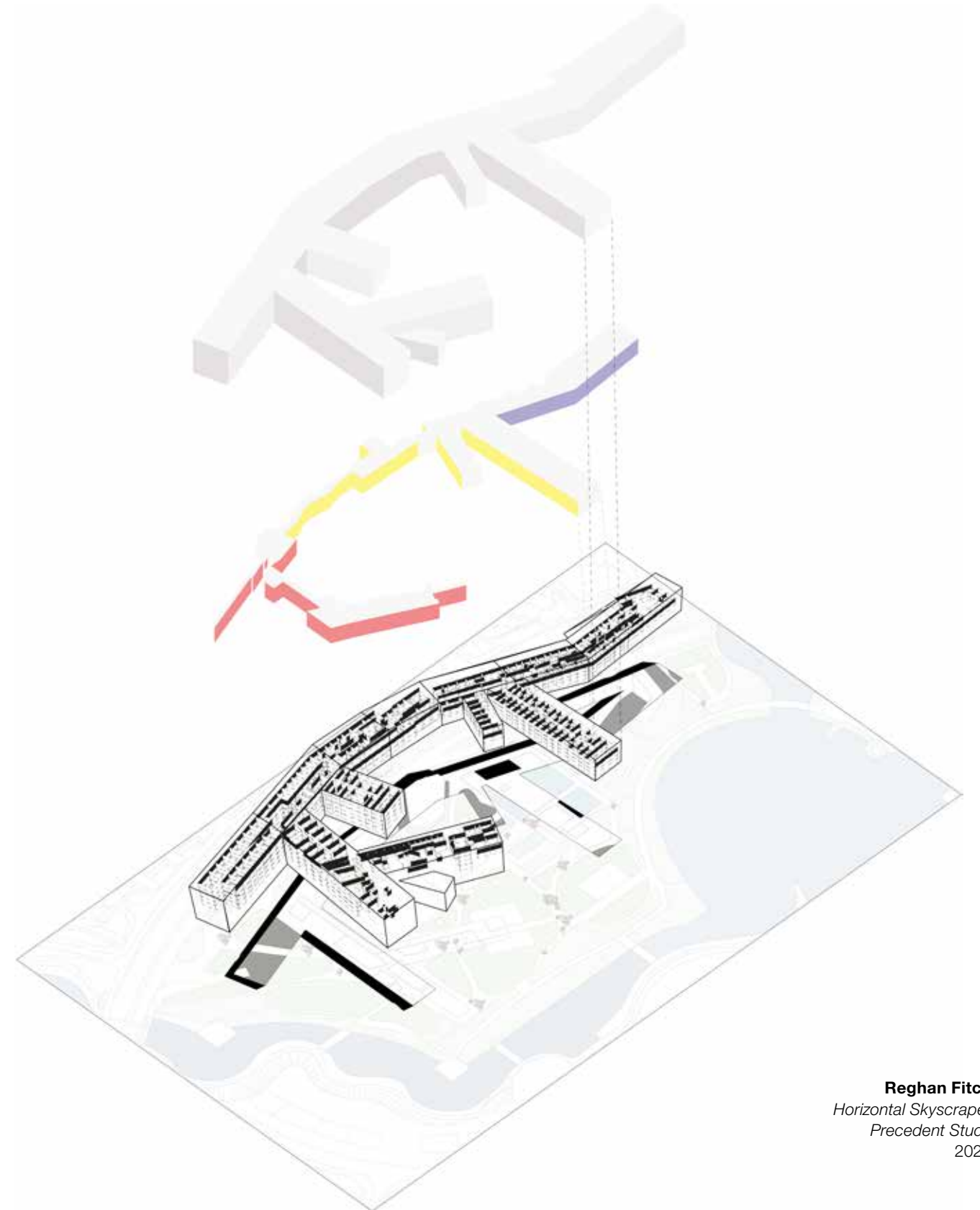

**Reghan Fitch**  
*Horizontal Skyscraper*  
*Precedent Study*  
2022



# ARCHITECTURE

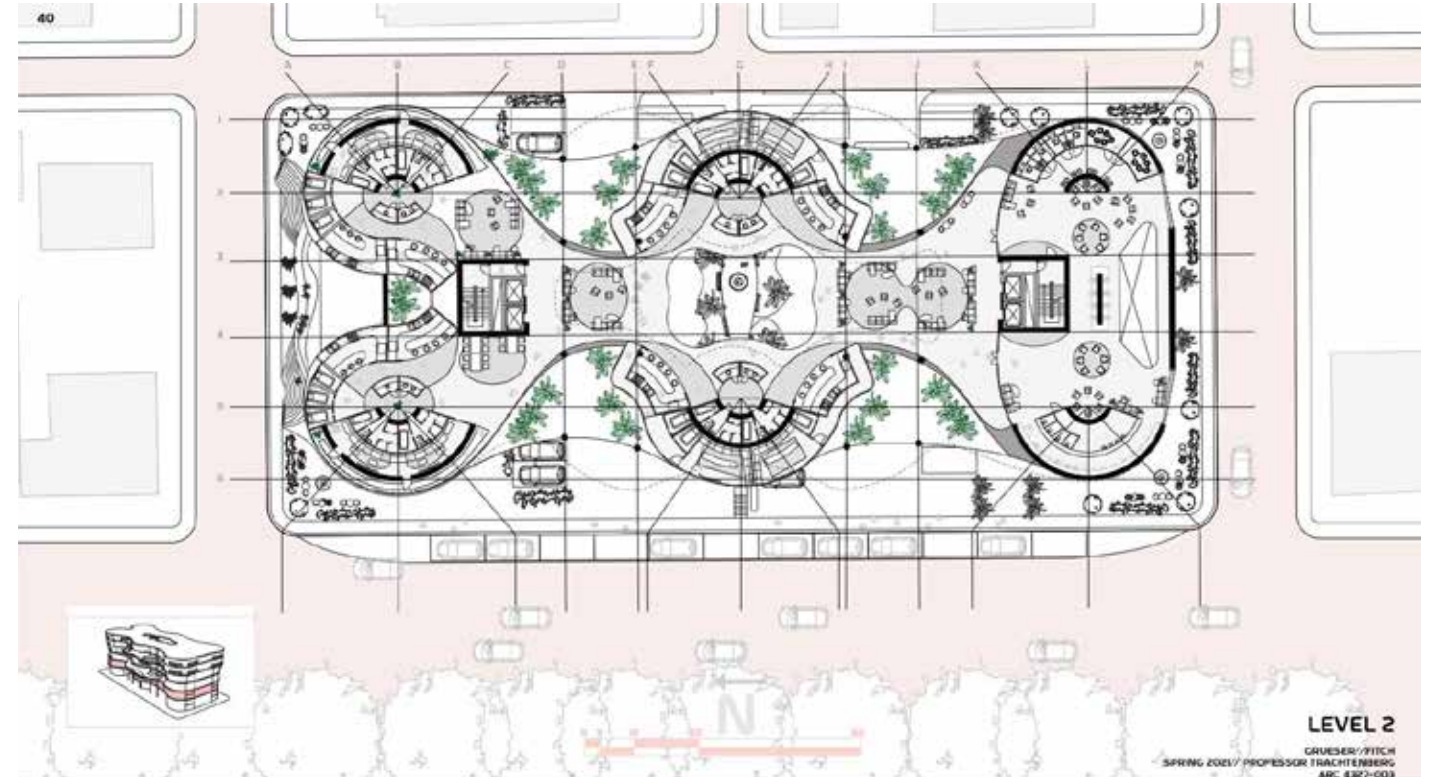

Reghan Fitch  
*P.R.I.E.N. United*  
2021

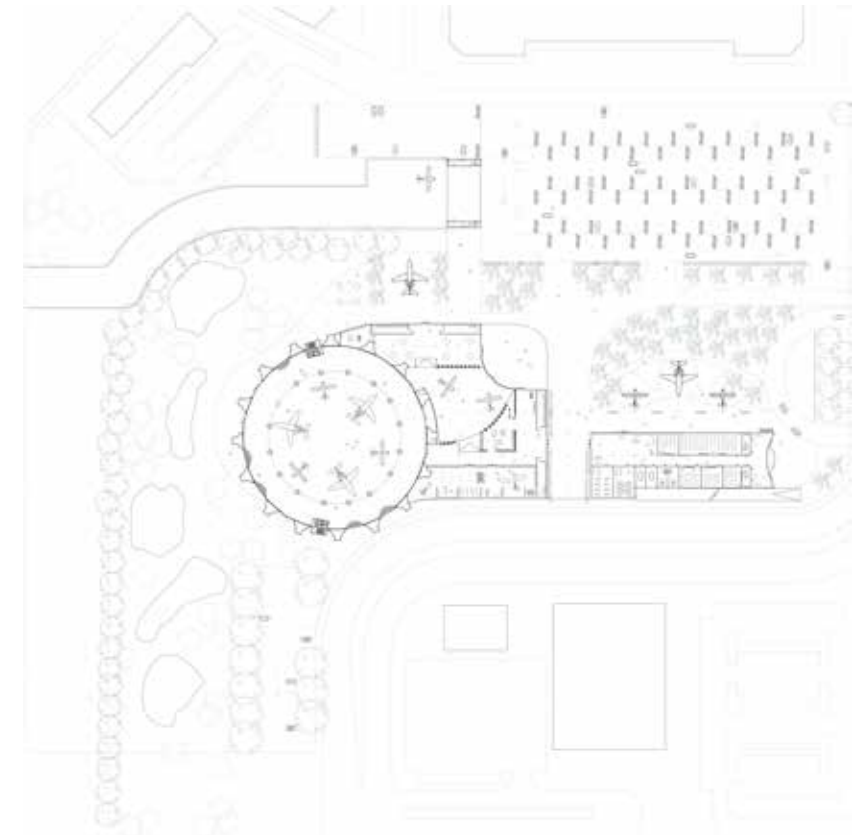





**Alizgreeth I. Tezen**  
*Project 13 Atmospheres*  
*2 Mirage and Narratives*  
2021





# FILM, VIDEO & NEW MEDIA

**JUROR'S CHOICE**

**Parinaz Moghadampour**  
*The Opposition*  
 2022

Java application, media projection,  
 LeapMotion controller

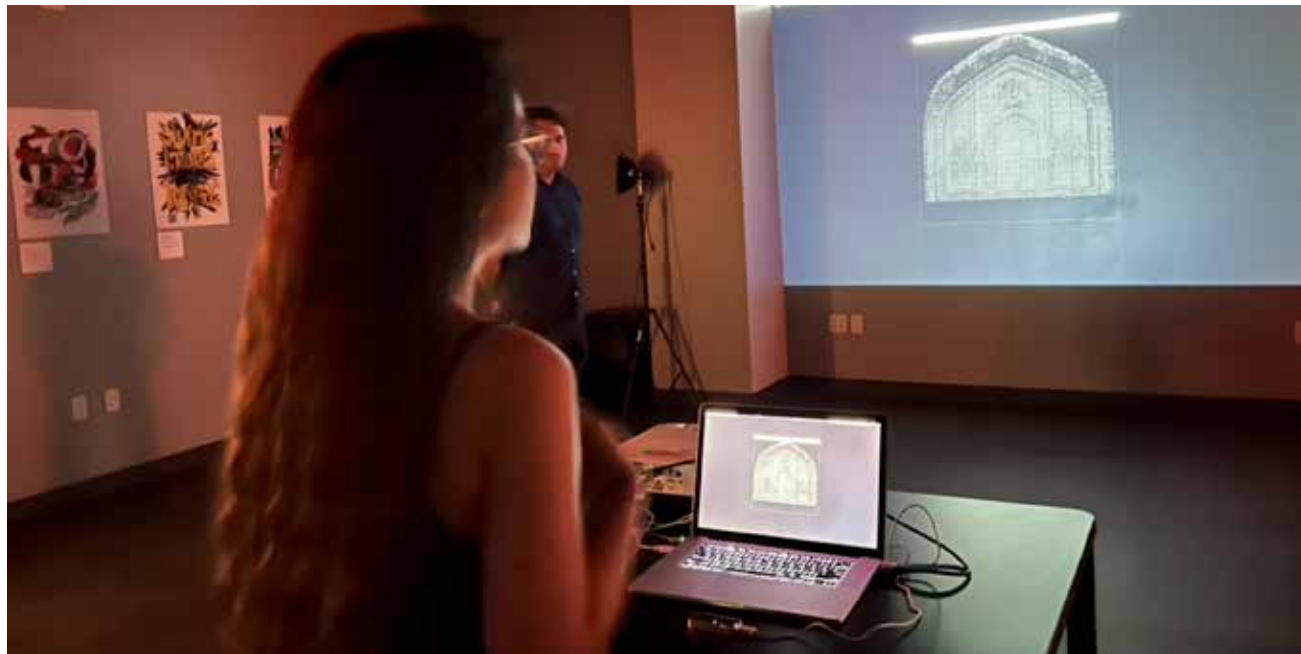

*The Opposition* examines different life experiences through the processes of destruction and rebuilding. This experience became tangible to me while building a life in a new country as an international student. In this project, the audience experiences two situations

—temporal-spatial—and two different narratives. A historic architectural space is digitally rendered using electronic tools. The new visual is transformed into different states through the viewer's interaction with the space.

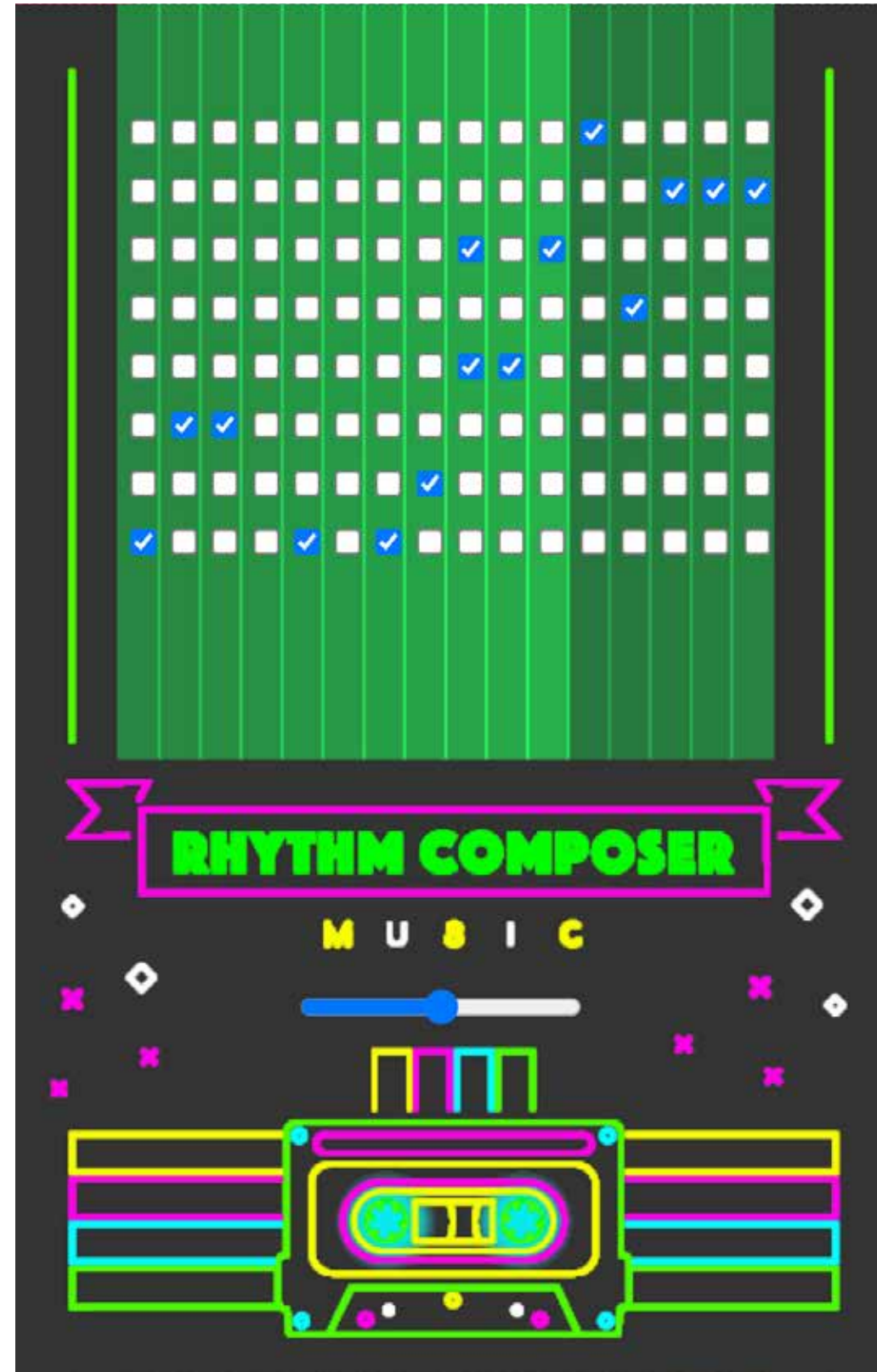

*Interactive Rhythm Composer* allows users to create rhythmic patterns in real-time by selecting and de-selecting checkboxes on the playful, neon-inspired interface.

**Ida Moraghebat**  
*Interactive Rhythm Composer*  
 2022

Javascript application for browser-  
 desktop, tablet, smartphone



## FILM, VIDEO & NEW MEDIA



The intention of this project is to symbolize the vulnerability of women. The sculpture is constructed with 130 pounds of clay built on a foam and wire base. It mounts on a podium and attaches to the wall with a red film that encapsulates the entire sculpture. The figure is on its knees to show vulnerability. It is wrapped in film to show reluctance and to convey



**Astrid Maldonado**

*Projection*  
2021

[tinyurl.com/37vmd54f](https://tinyurl.com/37vmd54f)

the ideas of a trapped self. The featured code is written using P5js called "caterpillar." It tracks mouse movement to create circles and allows the circle to change color with a mouse press. This allows the user to outline the sculpture and create light variations on the sculpture through the use of a projector.





Florida Atlantic University  
Broward Campuses  
111 East Las Olas  
Fort Lauderdale, FL 33301

